

RB8
Rev. 7/13/2011

SPECIFICATIONS

FOR

PIPELINE OCCUPANCY

ON

READING BLUE MOUNTAIN
& NORTHERN RAILROAD

PROPERTY

INDEX

1.0	GENERAL	
1.1	Scope -----	5
1.2	Definitions -----	5
1.3	Application for Occupancy -----	5
1.4	Right of Entry -----	6
1.5	Site Inspection -----	6
1.6	Information Required for Submission -----	6
1.7	Notification to Proceed with Construction -----	8
2.0	GENERAL REQUIREMENTS	
2.1	Use of a Casing Pipe -----	8
2.2	Location of Pipeline on the Right Of Way -----	8
2.3	Depth of Installation -----	9
2.4	Pipelines within Limits of a Dedicated Highway -----	10
2.5	Modification of Existing Facilities -----	10
2.6	Abandoned Facilities -----	10
2.7	Conflict of Specifications -----	10
2.8	Insulation -----	10
2.9	Corrosion Protection and Petroleum Leak Prevention -----	10
3.0	SOIL INVESTIGATION	
3.1	General -----	11
3.2	Location -----	11
3.3	Sampling -----	11
3.4	Boring Logs -----	11
3.5	Additional Information -----	12

4.0 DESIGN REQUIREMENTS

4.1 Design Loads ----- 12

4.2 Design Assumptions ----- 13

4.3 Casing Pipe ----- 14

4.4 Carrier Pipe ----- 19

4.5 Casing Pipe End Seals ----- 20

4.6 Vents ----- 21

4.7 Signs ----- 21

4.8 Warning Tape ----- 22

4.9 Shut-Off Valves ----- 22

4.10 Cathodic Protection ----- 22

4.11 Manholes ----- 23

4.12 Box Culverts ----- 23

4.13 Drainage ----- 23

4.14 Pipelines on Bridges ----- 23

5.0 CONSTRUCTION REQUIREMENTS

5.1 Method of Installation ----- 24

5.2 Grouting ----- 28

5.3 Soil Stabilization ----- 28

5.4 Dewatering ----- 28

5.5 Safety Requirements ----- 28

5.6 Blasting ----- 29

5.7 Temporary Track Supports ----- 29

5.8 Protection of Drainage Facilities ----- 29

5.9 Support of Excavation Adjacent to Track ----- 30

5.10 Inspection and Testing ----- 30

5.11 Reimbursement of RBMN Costs ----- 31

APPENDIX

PLATE I	Pipe Data Sheet -----	32
PLATE II	Plan (crossing) -----	33
PLATE III	Profile (crossing) -----	34
PLATE IV	Plan & Profile (longitudinal occupancy) -----	35
PLATE V	Section (longitudinal occupancy) -----	36
PLATE VI	Plan & Section (highway crossing under RR bridge) -----	37
PLATE VII	Elevation & Section (pipe on highway bridge over RR) -----	38
PLATE VIII	Test Boring Log -----	39
PLATE IX	Lateral Pressure Diagram -----	40
PLATE X	Folding of Plans -----	41
	Publication Standards Sources -----	42

- c. All applications shall be accompanied with six (6) copies of all design and construction plans and three (3) copies of all specifications and engineering computations for the proposed occupancy. On extensive projects, only those plans involving work on, or affecting RBMN property and operations, shall be submitted. Included shall be a plan showing the extent of the total project upon which that portion of the work affecting RBMN is clearly defined.
- d. All of the above plans, specifications and computations must be prepared by and bear the seal of a Professional Engineer.

1.4 RIGHT OF ENTRY

- a. No entry upon RBMN property for the purpose of conducting surveys, field inspections, obtaining soils information or any other purposes associated with the design and construction for the proposed occupancy, will be permitted without a proper entry permit prepared by RBMN. The applicant must pay the associated fees and execute the entry permit.
- b. It is to be clearly understood that the issuance of an entry permit does not constitute authority to proceed with any construction. Construction can not begin until a formal agreement is executed by RBMN and the Owner receives permission in writing from RBMN to proceed with the work.

1.5 SITE INSPECTION

- a. For longitudinal occupancy of RBMN property a site inspection along the proposed pipeline route may be required before final design plans are prepared. When a site inspection is required, the applicant and/or his engineer must meet with RBMN representatives to view the entire length of the proposed occupancy.
- b. Prior to the site inspection the applicant must submit the following information:
 - A plan view of the proposed route showing all tracks, both RBMN right-of-way lines and all other facilities located on the right-of-way. The distance from the proposed pipeline to the adjacent track and to the right-of-way lines must be shown.
 - A complete "Pipe Data Sheet" (See plate I)
 - Typical cross sections along the proposed route. (See plate V)
- c. Site inspections for pipe crossings are not required unless, in the opinion of RBMN, the size and location of the facility warrant an inspection.

1.6 INFORMATION REQUIRED FOR SUBMISSION

1.6.1 Plans and Computations

- a. Plans for proposed pipeline occupancies shall be submitted to and approved by RBMN prior to RBMN's issuance of an agreement and start of construction.
- b. Plans are to be prepared in sizes as small as practical (8½" X 11", 8½" X 14" or 8½" X 17") Larger size plans shall be folded, individually, by the applicant to an 8½" X 11" (216 x 279mm) size, as shown on Plate X, prior to submission. Where more than one plan is involved, the folded plans shall be assembled into complete sets by the applicant before submission. Failure of the applicant to comply with these requirements may be sufficient cause for rejection of the application.

- c. Plans shall be drawn to scale and shall include the following (See Plates I to VII):
- Plan view of proposed pipeline in relation to all RBMN facilities and facilities immediately adjacent to RBMN including, but not limited to, tracks, buildings, signals, pole lines, other utilities and all other facilities that may affect or influence the pipeline design and construction. (See Plate II)
 - The location, in feet (meters), of the pipe crossing from the nearest RBMN Milepost and/or from the centerline of a RBMN bridge, giving the RBMN bridge number. If the above is not available, provide distance to the nearest highway grade crossing of the railroad.
 - In all cases, the name of the State and County in which the proposed facilities are located must be shown. In States where Townships, Ranges and Sections are used, show the distance in feet to the nearest Section line and identify the Section number, Township and Range.
 - The profile of the ground above the centerline of the pipe, from field survey, showing relationship of the pipeline and/or casing pipe to the ground levels, the tracks and other facilities (See Plate III). For longitudinal occupations, the top of the rail profile of the adjacent track shall be shown on the pipeline profile. (See Plate IV).
 - All RBMN property lines indicated by dimensions, in feet (meters), to the centerline of adjacent track, as well as the overall width of the RBMN right-of-way. If the pipeline is in a public highway, the limits of the dedicated highway right-of-way, as well as the limits of any paving, sidewalks, etc., shall be defined, by dimensions in feet (meters), from the centerline of the dedicated right-of-way.
 - The angle of the crossing in relation to the centerline of the track(s). (See Plate II).
 - On pipelines having valves, the distance in feet (meters) along the pipeline from the crossing to the nearest valves and/or control stations.
 - A separate "Pipe Data Sheet" (See Plate I) shall be submitted on an 8½" x 11" (216x279mm) sheet, for each crossing.
- d. The plan shall be specific, on RBMN property and under tracks that are not on RBMN property as to the:
- Method of installation. (See Section 5.1)
 - Size and material of the casing pipe. (See Section 4.3)
 - Size and material of the carrier pipe. (See Section 4.4)
- These items can not have an alternative and any application that is received that indicates options in any of the above items will not be processed.
- e. Once the application has been approved by RBMN, no variance from the plans, specifications, method of installation, construction, etc., as approved in the occupancy document, will be considered or permitted without the payment to RBMN of additional fees for the re-processing of the application.
- f. All plans and computations associated with the work under the agreement shall be prepared by, and bear the seal of, a Professional Engineer. If not so imprinted, the application will be given no further consideration. This requirement also applies to all data submitted by the Owner's contractor. Contractor plans and computations that are not stamped will be returned and construction will not be permitted to proceed.

1.6.2 Specifications

- a. Project specifications, for all work on and affecting the railroad right-of-way, shall be included with the submission. All pertinent requirements of this document shall be included.

1.7 NOTIFICATION TO PROCEED WITH CONSTRUCTION

- a. After approval of the engineering plans and specifications and execution of the occupational agreement, the Owner will be notified of the appropriate RBMN Office that must be contacted prior to start of construction. The RBMN Real Estate Department will provide inspection of the project and coordinate all other construction aspects of the project that relate to RBMN flagging, track work, protection of signal cables, etc.
- b. The RBMN Real Estate Department must be notified a minimum of fourteen (14) working days prior to desired start of construction.

2.0 GENERAL REQUIREMENTS

2.1 USE OF A CASING PIPE

- a. A casing pipe will be required for all pipeline crossings. The casing pipe shall be laid across the entire width of the right-of-way.

2.2 LOCATION OF PIPELINE ON THE RIGHT-OF-WAY

- a. Pipelines laid longitudinally on RBMN's right-of-way shall be located as far as practicable from any tracks or other important structures and as close to the railroad property line as possible. Longitudinal pipelines must not be located in earth embankments or within ditches located on the right-of-way.
- b. Pipelines shall be located, where practicable, to cross tracks at approximate right angles to the track, but preferably not less than 45 degrees.
- c. Pipelines shall not be placed within a culvert, under railroad bridges, nor closer than 45 feet (13.7m) to any portion of any railroad bridge, building, or other important structure, except in special cases, and then by special design, as approved by RBMN Real Estate Department.
- d. Pipelines shall not be located within the limits of a turnout (switch) when crossing the track. The limits of the turnout extend from the point of the switch to the last long timber.
- e. Pipeline installations shall not be designed as an open cut installation where the pipeline is to be located within the limits of a grade crossing. If it is shown that no other method of installation is possible, the Owner will be responsible for reimbursing RBMN for all costs associated with the removal and reconstruction of the grade crossing.
- f. Pipelines carrying liquefied petroleum gas shall, where practicable, cross the railroad where tracks are carried on embankment.
- g. Uncased gas pipelines must not be located within 25 feet (7.6m) of any track.

2.3 DEPTH OF INSTALLATION

2.3.1 Pipelines conveying non-flammable substances

- a. Casing/carrier pipes placed under RBMN track(s) shall be not less than 5½ feet (1.7m) from base of rail to top of pipe at its closest point, except that under sidings or industry tracks this distance may be 4½ feet (1.4m) as approved by RBMN. On other portions of the right-of-way, where the pipe is not directly beneath any track, the depth from ground surface or from bottom of ditch to top of pipe shall not be less than 3 feet (0.9m). Where 3 feet (0.9m) of cover can not be provided from bottom of ditch, a 6 inch (152mm) thick concrete slab shall be provided over the pipeline for protection.
- b. Pipelines laid longitudinally on RBMN's right-of-way, 50 feet (15.2m) or less from centerline track, shall be buried not less than 4 feet (1.2m) from ground surface to top of pipe. Where the pipeline is laid more than 50 feet (15.2m) from centerline of track, the minimum cover shall be at least 3 feet (0.9m).

2.3.2 Pipelines conveying flammable substances

- a. Casing pipes under RBMN track(s) shall be not less than 5½ feet (1.7m) from base of rail to top of pipe at its closest point, except that under sidings or industry tracks this distance may be 4½ feet (1.4m) as approved by RBMN. On other portions of the right-of-way, where the pipe is not directly beneath any track, the depth from ground surface or from bottom of ditch to top of pipe shall not be less than 3 feet (0.9m). Where 3 feet (0.9m) of cover can not be provided from bottom of ditch, a 6 inch (152mm) thick concrete slab shall be provided over the pipeline for protection.
- b. Uncased gas pipelines, under RBMN track(s), shall not be less than 10 feet (3.0m) from the base of the rail to the top of the pipe at its closest point. At all other locations where crossing the right-of-way, the minimum ground cover must be 6 feet (1.8m). Where it is not possible to obtain the above depths, use of a casing pipe will be required.
- c. Pipelines laid longitudinally on RBMN's right-of-way, 50 feet (15.2m) or less from centerline track, shall be buried not less than 6 feet (1.8m) from ground surface to top of pipe. Where the pipeline is laid more than 50 feet (15.2m) from centerline of track, the minimum cover shall be at least 5 feet (1.5m).

2.4 PIPELINES WITHIN LIMITS OF A DEDICATED HIGHWAY

- a. Pipelines within the limits of a dedicated highway are subject to all the requirements of this specification and must be designed and installed in accordance with them.
- b. The limits of the dedicated highway (right-of-way) must be clearly shown on the plans.
- c. Construction cannot begin until an agreement has been executed between RBMN and the Owner and proper notification has been given to RBMN Real Estate Department. (See Section 1.7).

2.5 MODIFICATION OF EXISTING FACILITIES

- a. Any replacement or modification of an existing carrier pipe and/or casing shall be considered as a new installation, subject to the requirements of this specification.

2.6 ABANDONED FACILITIES

- a. The owner of all abandoned pipe crossings and other occupancies shall notify RBMN Real Estate Department in writing, of the intention to abandon.
- b. Abandoned pipelines shall be removed or completely filled with cement grout, compacted sand or other methods as approved by RBMN.
- c. Abandoned manholes and other structures shall be removed to a minimum distance of 2 feet (0.6m) below finished grade and completely filled with cement grout or compacted sand.

2.7 CONFLICT OF SPECIFICATIONS

- a. Where laws and orders of public authority prescribe a higher degree of protection than specified herein, then the higher degree so prescribed shall be deemed a part of this specification.

2.8 INSULATION

- a. Pipelines and casings shall be suitably insulated from underground conduits carrying electric wires on RBMN property.

2.9 CORROSION PROTECTION AND PETROLEUM LEAK PREVENTION

- a. Pipelines on RBMN property that carry petroleum products or hazardous liquids shall be designed in accordance with current federal, state and/or local regulations that mandate leak detection automatic shutoff, leak monitoring, and sacrificial anodes and/or exterior coatings to minimize corrosion and prevent petroleum releases.

3.0 SOIL INVESTIGATION

3.1 GENERAL

- a. Test borings or other soil investigations, approved by RBMN, shall be made to determine the nature of the underlying material for all pipe crossings 60 inches (1524mm) in diameter and larger under track(s). (See Section 1.4 relative to procedures)
- b. Test borings or other soil investigations, approved by RBMN, may be required when, in the judgment of RBMN, they are necessary to determine the adequacy of the design and construction of pipe crossings less than 60 inches (1524mm) in diameter and for other facilities located on the right-of-way.

3.2 LOCATION

- a. Borings shall be made on each side of the track(s), on the centerline of the pipe crossing, and as close to the track(s) as practicable. (See Section 1.4 relative to procedures)
- b. Test boring logs shall be accompanied with a plan, drawn to scale, showing the location of the borings in relation to the track(s) and the proposed pipe.

3.3 SAMPLING

- a. Test borings shall be made in accordance with current ASTM Designation D 1568 except that sampling must be continuous from the ground surface to 5 feet (1.5m) below the proposed invert unless rock is encountered before this depth. Where rock is encountered, it is to be cored using a Series "M" Double Tube Core Barrel, with a diamond bit, capable of retrieving a rock core at least 1 \square " (41.3mm) in diameter. Individual core runs are not to exceed 5 feet (1.5m) in length.

3.4 BORING LOGS

- a. Test boring logs shall comply with Plate VIII and clearly indicate all of the following:
 - Boring number as shown on the required boring location plan.
 - Ground elevation at each boring using same datum as the pipeline construction plans.
 - Engineering description of soils and rock encountered.
 - Depth and percent recovery of all soil samples.
 - Depth from surface for each change in strata.
 - Blows for each 6 inches (152mm) of penetration for the standard penetration test described in ASTM D 1586. Blows for lesser penetrations should be recorded.
 - Percent recovery and Rock Quality Designation (RQD) for all rock cores.
 - Depth to ground water while sampling and when it has stabilized in the bore hole.
- b. The location of the carrier pipe and/or casing pipe shall be superimposed on the boring logs before submission to RBMN.
- c. All borings shall be sealed, for their full depth, with a 4-3-1 bentonite-cement-sand grout after accurate ground water readings have been taken and recorded.
- d. Soil samples taken from auger vanes or return washwater are not acceptable.

3.5 ADDITIONAL INFORMATION

- a. When directed by RBMN, additional borings may be required for the purpose of taking undisturbed thin-wall piston samples or Dennison type samples for laboratory testing to determine the index and engineering properties of certain soil strata.

4.0 DESIGN REQUIREMENTS

4.1 DESIGN LOADS

4.1.1 General Requirements

- a. All pipes, manholes and other facilities shall be designed for the external and internal loads to which they will be subjected.
- b. To allow for placement of additional track(s) or shifting of the existing track(s), all proposed pipelines or structures shall be designed as if a railroad loading is directly above the facility.

4.1.2 Earth Load

- a. The dead load of the earth shall be considered as 120 pounds per cubic foot (18.9kN/m³) unless soil conditions warrant the use of a higher value.

4.1.3 Railroad Load (live load and impact)

- a. The railroad live load used shall be a Cooper E-80 loading. This loading consists of 80 kip (356kN) axle loads spaced 5 feet (1.5m) on centers.
- b. An impact factor of 1.75 (multiply live load by the impact factor) shall be used for depth of cover up to 5 feet (1.5m). Between 5 and 30 feet (1.5 and 9.1m), the impact factor is reduced by 0.03 per foot (0.1per m) depth. Below a depth of 30 feet (9.1m), the impact factor is one.
- c. The values shown in Table 1 shall be used for the vertical pressure on a buried structure for the various heights of cover.

TABLE 1

Live loads, including impact, for various heights of cover for a Cooper E-80 loading.

HEIGHT OF COVER		LOAD	
FEET	(METER)	LB/SQ FT.	(kPa)
2	(0.6)	3800	(162.8)
3	(0.9)	3150	(150.8)
4	(1.2)	2850	(136.5)
5	(1.5)	2550	(122.1)
6	(1.8)	2250	(107.7)
7	(2.1)	1950	(93.4)
8	(2.4)	1700	(81.4)
9	(2.7)	1500	(71.8)
10	(3.0)	1300	(62.2)
12	(3.7)	1000	(47.9)
14	(4.3)	800	(38.3)
16	(4.9)	625	(29.9)
18	(5.5)	500	(23.9)
20	(6.1)	400	(19.2)
25	(7.6)	250	(12.0)
30	(9.1)	150	(7.2)

- d. To determine the horizontal pressure caused by the railroad loading on a sheet pile wall or other structure adjacent to the track, the Boussinesq analyses shall be used. The load on the track shall be taken as a strip load with a width equal to the length of the ties, 8½ feet (2.6m). The vertical surcharge, q (psf), caused by each axle, shall be uniform and equal to the axle load divided by the tie length and the axle spacing, 5 feet (1.5m). For the E-80 loading this results in:

$$Q=80,000 / (8.5 \times 5) = 1882 \text{ psf.} \quad (q=356 / (2.591 \times 1.524) = 90.1 \text{ k Pa})$$

The horizontal pressure due to the live load surcharge at any point on the wall or other structure is p and can be calculated by the following:

$$p = \frac{(2q/\pi)(\beta - \sin \beta (\cos 2\alpha))}{h} \quad (\text{See PLATE IX})$$

- e. The vertical and horizontal pressures given above shall be used unless an alternate design method is approved by RBMN. Proposals to use an alternate design method must include acceptable references and a statement explaining the justification for choosing the alternate method.

4.2 DESIGN ASSUMPTIONS

- a. To design a casing pipe or an uncased carrier pipe for the external loads on RBMN's right-of-way, the following design assumptions shall be used, unless site conditions indicate more conservative values are required:

- b. Flexible Pipe (Steel, DIP, CMP, Tunnel Liner Plate)

- Steel Pipe (Bored and jacked in place)
 - ▶ Spangler's Iowa formula shall be used for design with:

Deflection lag factor	-	Dr=1.5
Modulus of soil reaction	-	E' = 1080psi (7.45MPa)
Bedding constant	-	Kb = 0.096
Soil loading constant	-	Kú = 0.13
Allowable deflection of pipe	-	3%of pipe diameter
- Ductile Iron Pipe (Open Cut)
 - ▶ ANSI Specification A 21.50 shall be used for design with:
 - Pipe laying condition = Type 3 (See Section 5.1.2 for backfill requirements on railroad right-of-way)
 - Earth load – ANSI A 51.50 prism method
- Corrugated Steel Pipe & Corrugated Structural Steel Plate Pipe (Open Cut)
 - ▶ AREA Chapter 1. Part 4. Sections 4.9 & 4.10 shall be used for design with:
 - Soil stiffness factor - K = 0.33
 - Railroad impact as per Section 4.1.3.b. of this specification
- Tunnel Liner Place (Tunneled)
 - ▶ AREA Chapter 1, Part 4. Section 4.16 shall be used for design with:
 - Soil stiffness factor – K = 0.33
 - Railroad impact as per Section 4.1.3.b of this specification

- c. Rigid Pipe (RCP), Vitrified Clay Pipe and PCCP)

- Reinforced Concrete Pipe, Vitrified Clay Pipe & Prestressed Concrete Cylinder Pipe (Open Cut)
 - ▶ American Concrete Pipe Association design manual shall be used for design with:
 - Marston load theory used for earth load
 - Bedding (Load Factor) - $L_f = 1.9$
 - Factor of safety - FS = 1.25 for RCP FS = 1.50 for VCP
 - Railroad impact as per Section 4.1.3.b of this specification

- Reinforced Concrete Pipe (Jacked)
 - ▶ American Concrete Pipe Association design manual shall be used for design with:
 - Marston load theory used for earth load
 - Bedding (Load Factor) - $L_f = 3.0$
 - Factor of safety = 1.25
 - Railroad impact as per Section 4.1.3.b of this specification

4.3 CASING PIPE

4.3.1 General Requirements

- a. Casing pipe shall be so constructed as to prevent leakage of any substance from the casing throughout its length, except at ends of casing where ends are left open, or through vent pipes when ends of casing are sealed. Casing shall be installed so as to prevent the formation of a waterway under the railroad, and with an even bearing throughout its length, and shall slope to one end (except for longitudinal occupancy).
- b. The casing pipe and joints shall be of steel and of leakproof construction when the pipeline is carrying liquid flammable products or highly volatile substances under pressure.
- c. The inside diameter of the casing pipe shall be such as to allow the carrier pipe to be removed subsequently without disturbing the casing or the roadbed. For steel pipe casings, the inside diameter of the casing pipe shall be at least 2 inches (51mm) greater than the largest outside diameter of the carrier pipe joints or couplings, for carrier pipe less than 6 inches (152mm) in diameter; and at least 4 inches (102mm) greater for carrier pipe 6 inches (152mm) and over in diameter.
- d. For flexible casing pipe, a maximum vertical deflection of the casing pipe of 3 percent of its diameter, plus ½ inch (13mm) clearance shall be provided so that no loads from the roadbed, track, traffic or casing pipe itself are transmitted to the carrier pipe. When insulators are used on the carrier pipe, the inside diameter of the flexible casing pipe shall be at least 2 inches (51mm) greater than the outside diameter of the carrier pipe for pipe less than 8 inches (203mm) in diameter; at least ¾ inches (83mm) greater for pipe 8 inches to 16 inches (203mm to 406mm), inclusive, in diameter and at least 4½ inches (114mm) greater for pipe 18 inches (457mm) and over in diameter.
- e. In no event shall the casing pipe diameter be larger than is necessary to permit the insertion of the carrier pipe.

- f. Casing pipe under railroad tracks and across RBMN's right-of-way shall extend the GREATER of the following distances, measured at right angle to centerline track:
- Across the entire width of the RBMN right-of-way
 - 3 feet (0.9m) beyond ditch line
 - 2 feet (0.6m) beyond toe of slope
 - A minimum distance of 25 feet (7.6m) from each side of centerline of outside track when casing is sealed at both ends.
 - A minimum distance of 45 feet (13.7m) from centerline of outside track when casing is open at both ends.
 - Beyond the theoretical railroad embankment line. This line begins at a point, on existing grade, 10 feet (3m) horizontally from centerline track and extends downward on a 1½ (H) to 1 (V) slope. (See Plate III).
- g. If additional tracks are constructed in the future, the casing shall be extended correspondingly at the Owner's expense.

4.3.2. Steel Pipe

- a. Steel pipe may be installed by open cut, boring or jacking.
- b. Steel pipe shall have a specified minimum yield strength, SMYS, of at least 35,000 psi (241MPa). The ASTM or API specification and grade for the pipe are to be shown on the Pipe Data Sheet (Plate I).
- c. Joints between the sections of pipe shall be fully welded around the complete circumference of the pipe.
- d. Steel casing pipe, with a minimum cover of 5½ ft (1.7m), shall have a MINIMUM wall thickness as shown in TABLE 2, unless computations indicate that a thicker wall is required.

TABLE 2

Live loads, including impact, for various heights of cover for a Cooper E-80 loading.

PIPE DIAMETER		COATED OR CATHODICALLY PROTECTED		UNCOATED AND UNPROTECTED	
NOMINAL PIPE SIZE		NOMINAL WALL THICKNESS		NOMINAL WALL THICKNESS	
INCHES	(MM)	INCHES	(MM)	INCHES	(MM)
10 & under	(254 & under)	0.188	(4.78)	0.188	(4.78)
12 & 14	(305 & 356)	0.188	(4.78)	0.250	(6.35)
16	(406)	0.219	(5.54)	0.281	(7.14)
18	(457)	0.250	(6.35)	0.312	(7.92)
20 & 22	(508 & 559)	0.281	(7.14)	0.344	(8.74)
24	(610)	0.312	(7.92)	0.375	(9.53)
26	(660)	0.344	(8.74)	0.406	(10.31)
28	(711)	0.375	(9.53)	0.438	(11.07)
30	(762)	0.406	(10.31)	0.469	(11.91)
32	(813)	0.438	(11.07)	0.500	(12.70)
34 & 36	(864 & 914)	0.469	(11.91)	0.532	(13.49)
38	(965)	0.500	(12.70)	0.562	(14.27)
40	(1016)	0.531	(13.49)	0.594	(15.09)
42	(1067)	0.562	(14.27)	0.625	(15.88)
44 & 46	(1118 & 1168)	0.594	(15.09)	0.657	(16.66)
48	(1219)	0.625	(15.88)	0.688	(17.48)
50	(1270)	0.656	(16.66)	0.719	(18.26)
52	(1321)	0.688	(17.48)	0.750	(19.05)
54	(1372)	0.719	(18.26)	0.781	(19.84)
56 & 58	(1422 & 1473)	0.750	(19.05)	0.812	(20.62)
60	(1524)	0.781	(19.84)	0.844	(21.44)
62	(1575)	0.812	(20.62)	0.875	(22.23)
64	(1626)	0.844	(21.44)	0.906	(23.01)
66 & 68	(1676 & 1727)	0.875	(22.23)	0.938	(23.83)
70	(1778)	0.906	(23.01)	0.969	(24.61)
72	(1829)	0.938	(23.83)	1.000	(25.40)

- e. Coated steel pipe that is bored or jacked into place shall conform to the wall thickness requirements for uncoated steel pipe since the coating may be damaged during installation.
- f. Smooth wall steel pipes with a nominal diameter over 72 inches (1829mm) will not be permitted.

4.3.2 Ductile Iron Pipe

- a. Ductile iron pipe may be used only when placed by the open cut method. Jacking or boring through the railroad embankment is not permitted due to the bell and spigot joints.

- b. Ductile iron pipe shall conform to the requirements of ANSI A21.51/AWWA C-151. Class 56 pipe shall be used unless computations, in accordance with Sections 4.1 and 4.2 are provided.
- c. Table 3 is based on the design assumptions given in Section 4.2.b (2) with a minimum cover of 5½ ft. (1.7m). This table is provided for information only.

TABLE 3

PIPE DIAMETER		THICKNESS CLASS			PRESSURE CLASS		
		WALL THICKNESS	CLASS		WALL THICKNESS	CLASS	
in.	(mm)	in.	(mm)		in.	(mm)	
3	(89)	0.25	(6.35)	51	0.25	(6.35)	350
4	(144)	0.26	(6.60)	51	0.25	(6.35)	350
6	(168)	0.25	(6.35)	50	0.25	(6.35)	350
8	(219)	0.27	(6.86)	50	----	----	----
10	(273)	0.32	(8.13)	51	----	----	----
12	(324)	0.34	(8.64)	51	----	----	----
14	(356)	0.39	(9.91)	52	----	----	----
16	(406)	0.40	(10.2)	52	----	----	----
18	(457)	0.44	(11.2)	53	----	----	----
20	(508)	0.45	(11.4)	53	----	----	----
24	(610)	0.53	(13.5)	55	----	----	----
30	(762)	0.63	(16.0)	56	----	----	----
36	(914)	0.73	(18.5)	56	----	----	----
42	(1067)	0.83	(21.1)	56	----	----	----
48	(1219)	0.93	(23.6)	56	----	----	----
54	(1372)	1.05	(26.7)	56	----	----	----

- d. The pipe shall have mechanical or push on type joints.

4.3.3 Corrugated Steel Pipe and Corrugated Structural Steel Plate Pipe

- a. Corrugated steel pipe and corrugated structural steel plate pipe may be used for a casing only when placed by the open cut method. Jacking or boring through the railroad embankment is not permitted.
- b. Corrugated steel pipe and corrugated structural steel plate pipe may be used for a casing provided the pressure in the carrier pipe is less than 100 psi (689 kPa).
- c. Pipe shall be bituminous coated and shall conform to the current American Railway Engineering Association Specifications Chapter 1, Part 4.
- d. Corrugated steel pipe shall have a minimum sheet thickness as shown in Table 4. Corrugated structural steel plate pipe shall have a minimum plate thickness of 8 gage, 0.168 in. (4.27mm). If computations indicate that a greater thickness is required, the thicker sheet or plate shall be used.

TABLE 4

PIPE DIAMETER		SHEET THICKNESS		
Inches	(mm)	Gage	Inches	(mm)
12 to 30	(305 to 762)	14	0.079	(2.01)
36	(914)	12	0.109	(2.77)
42 to 54	(1067 to 1372)	10	0.138	(3.51)
60 to 120	(1524 to 3048)	8	0.168	(4.27)

4.3.4 Steel Tunnel Liner Plates

- a. Liner plates shall be installed by the tunneling method as detailed in section 5.1.5 of this specification.
- b. Tunnel liner plates shall be galvanized and bituminous coated and shall conform to current AREA Specification Chapter 1, Part 4, Section 4.16. If the tunnel liner plates are used only to maintain a tunneled opening until the carrier pipe is installed, and the annular space between the carrier pipe and the tunnel liner is completely filled with cement grout within a reasonably short time after completion of the tunnel, then the tunnel liner plates need not be galvanized and coated.
- c. Tunnel liner plates are to be a minimum of 12 gage and shall be fabricated from structural quality, hot-rolled, carbon-steel sheets or plates conforming to ASTM Specification A 569.
- d. The following liner plate information must be shown on the Pipe Data Sheet (Plate I):
 - Number of flanges (2 or 4)
 - Width of plate
 - Type of plate (smooth or corrugated)

4.3.5 Reinforced Concrete Pipe

- a. Reinforced concrete pipe shall be installed by the open cut or jacking method.
- b. Reinforced concrete pipe shall conform to ASTM Specification C76. Class V pipe. Wall B or C shall be used unless computations, in accordance with Section 4.2 are provided.
- c. Reinforced concrete pipe may be used for a casing provided the pressure in the carrier pipe is less than 100 psi (689kPa).
- d. Pipe placed by open cut shall be installed in accordance with AREA Chapter 8, Part 10, Section 10.4 except that back fill and compaction shall be in accordance with Section 5.1.2. of this specification.
- e. Pipe jacked into place shall have tongue and groove joints and shall be installed in accordance with Section 5.1.4 of this specification.
- f. Joints between section of the RCP shall be sealed with a gasket conforming with ASTM C443 or approved equal.

4.3.6 Concrete Encasement

- a. At locations where the installation is by open cut and a casing pipe is required, but can not be installed due to elbows or other obstructions, concrete encasement may be used when approved by RBMN.
- b. The concrete encasement must provide a minimum cover of 6 inches of concrete (152mm) around the pipe. A 6 x 6 - W 2.9 x W 2.9 (152 x 152MW 18.7 x MW 18.7) welded wire fabric shall be placed in the concrete on all sides.

4.4 CARRIER PIPE

4.4.1 General Requirements

- a. The pipe shall be laid with sufficient slack so that it is not in tension.
- b. Steel pipe shall not be used to convey sewage, storm water or other liquids which could cause corrosion.
- c. Carrier pipes located on RBMN's right-of-way or under tracks which RBMN operates, shall be manufactured in accordance with the following specifications:
 - Steel Pipe - the ASTM or API specification and grade for the pipe to be shown on the Pipe Data Sheet. The specified minimum yield strength is to be at least 35,000 psi (241MPa). For flammable substances see Sections 4.4.2 and 4.4.3 for additional requirements.
 - Ductile Iron Pipe - ANSI A21.51/AWWA C151
 - Corrugated Metal Pipe - AREA Chapter 1, Part 4
 - Reinforced Concrete Pipe - ASTM C 76
 - Vitrified Clay Pipe - ASTM C 700
 - Prestressed Concrete Cylinder Pipe - AWWA C301
 - Reinforced Concrete Cylinder Pipe - AWWA C300
 - Others - as approved by RBMN
- d. Carrier pipes installed within a casing pipe shall be designed for the internal pressure to which it will be subjected.
- e. Gravity flow carrier pipes, installed without a casing pipe, shall meet the requirements, of the particular pipe material, as given in Section 4.3 of this specification.
- f. Design computations, stamped by a P.E. must be submitted for all uncased pressure pipelines installed on RBMN's right-of-way. The pipe must be designed for the internal and external loads (see Section 4.1) to which it may be subjected. The design assumptions given in Section 4.2 shall apply.

4.4.2 Pipelines Carrying Flammable Substances

- a. Pipelines carrying oil, liquefied petroleum gas and other flammable products shall be of steel and conform to the requirements of the current ANSI B 31.4 Liquid Transportation Systems for Hydrocarbons, Liquid Petroleum Gas, Anhydrous Ammonia, and Alcohols, and other applicable ANSI codes, except that the maximum allowable stresses for design of steel pipe shall not exceed the following percentages

of the specified minimum yield strength (multiplied by the longitudinal joint factor) of the pipe as defined in the above codes:

The following percentages apply to hoop stress in steel pipe within a casing under railroad tracks, across right-of-way and longitudinally on railroad right-of-way.

- 72% on oil pipelines
- 50% for pipelines carrying condensate, natural gasoline, natural gas liquids, liquefied petroleum gas, and other liquid petroleum products.
- 60% for installations on gas pipelines

The following percentages apply to hoop stress in steel pipe laid longitudinally on railroad right-of-way without a casing:

- 60% for oil pipelines.
- 40% for pipelines carrying condensate, natural gasoline, natural gas liquids, liquefied petroleum gas, and other liquid petroleum products.
- For gas pipelines see Section 4.4.3.b.

- b. Computations, based on the above requirements and stamped by a P.E., shall be submitted with the application for occupancy.

4.4.3 Uncased Pipelines Carrying Gas

- a. Pipelines carrying flammable and non-flammable gas products shall be steel and shall conform to the requirements of the current ANSI B31.8 Gas Transportation and Distribution Piping Systems, and other applicable ANSI codes.
- b. The minimum wall thickness for uncased carrier pipe shall be in accordance with the values provided in AREA, Chapter 1, Part 5, Section 5.2. Tables 5.2.3. (a through j).
- c. A durable coating, which will resist abrasion (fusion bonded epoxy or other suitable material), shall be used to protect the uncased pipeline when the boring method of installation is used.
- d. If RBMN determines there is the potential for damage to the uncased pipeline (foreign material in the subgrade, third party damage, etc.) special protection of the pipeline will be required. Special protection may include the use of concrete jacketed carrier pipe, a protection slab over the pipeline, increased depth of bury or other means.

4.5 CASING PIPE END SEALS

- a. Casings for carrier pipes of flammable and hazardous substances shall be suitably sealed to the outside of the carrier pipe. Details of the end seals shall be shown on the plans.
- b. Casings for carrier pipes of non-flammable substances shall have both ends of the casing blocked up in such a way as to prevent the entrance of foreign material, but allowing leakage to pass in the event of a carrier break.

- c. The ends of a casing pipe may be left open when the ends are at or above ground surface and above high water level, provided drainage is afforded in such a manner that leakage will be conducted away from railroad tracks and structures.

4.6 VENTS

- a. Sealed casings for flammable substances shall be properly vented. Vent pipes shall be of sufficient diameter, but in no case less than two inches (51mm) in diameter, and shall be attached near each end of the casing and project through the ground surface at right-of-way lines or not less than 45 feet (13.7m), measured at right angles from centerline of nearest track.
- b. Vent pipes shall extend not less than 4 feet (1.2m) above the ground surface. Top of vent pipe shall have a down-turned elbow, properly screened, or a relief valve. Vents in locations subject to high water shall be extended above the maximum elevation of high water and shall be supported and protected in a manner approved by RBMN.
- c. Vent pipes shall be at least 4 feet (1.2m), vertically, from aerial electric wires or greater if required by National Electrical Safety Code (ANSI C2).
- d. When the pipeline is in a public highway, street-type vents shall be installed.

4.7 SIGNS

- a. All pipelines (except those in streets where it would not be practical to do so) shall be prominently marked at right-of-way lines (on both sides of track for crossings) by durable, weatherproof signs located over the centerline of the pipe. If more than one pipe, indicate contents, pressure, depth of each pipe. Signs shall show the following:
 - Name and address of owner
 - Contents of pipe
 - Pressure in pipe
 - Pipe depth below grade at point of a sign
 - Emergency telephone number in event of pipe rupture
 - If a lease is in place for the pipe, the lease number should be indicated.
- b. For pipelines running longitudinally on RBMN property, signs shall be placed over the pipe (or offset and appropriately marked) at all changes in direction of the pipeline. Such signs should also be located so that when standing at one sign the next adjacent marker in either direction is visible. In no event shall they be placed more than 500 feet (152.4m) apart unless otherwise specified by RBMN.
- c. The Owner must maintain all signs on RBMN's right-of-way as long as the occupational agreement is in effect.

RAILROAD PIPE CROSSING SIGN DETAIL:

Arial Bold Text Style 1" letters for upper portion of sign ½" letters for lower portion

<p>CAUTION UNDERGROUND PIPELINE IN CASE OF EMERGENCY CALL () -</p>
<p>Owned by: _____</p> <p>Lease No. _____</p> <p>Pipe Contents: _____</p> <p>Pipe Pressure: _____</p> <p>Pipe Depth: _____</p>

4.8 WARNING TAPE

- a. All pressure pipelines installed by trench method, without a casing, shall have a warning tape placed directly above the pipeline, 2 feet (0.6) below the ground surface.

4.9 SHUT-OFF VALVES

- a. Accessible emergency shut-off valves shall be installed within effective distances each side of the railroad at locations selected by RBMN where hazard to life and property must be guarded against. No additional valves will be required where pipelines are provided with automatic control stations and within distances approved by RBMN.

4.10 CATHODIC PROTECTION

- a. Cathodic protection shall be applied to all pipelines carrying flammable substances on RBMN's right-of-way.
- b. For crossings and at other locations where the pipeline must be placed within a casing, the casing is to have cathodic protection or the wall thickness is to be increased to the requirements of Section 4.3.2 Table 2.
- c. Uncased gas carrier pipes must be coated and cathodically protected to industry standards and test sites, for monitoring the pipeline, provided within 50 feet (15.2m) of the crossing.
- d. Where casing and/or carrier pipes are cathodically protected by other than anodes, RBMN shall be notified and a suitable test made to ensure that other railroad structures and facilities are adequately protected from the cathodic current in accordance with the recommendation of current Reports of Correlating Committee on Cathodic Protection, published by the National Association of Corrosion Engineers.

- e. Where sacrificial anodes are used the locations shall be marked with durable signs.

4.11 MANHOLES

- a. Manholes shall not be located on RBMN property where possible. At locations where this is not practical, including longitudinal occupancies, manholes shall be precast concrete sections conforming to ASTM Designation C 478, "Specification for Precast Concrete Manhole Sections".
- b. The top of manholes located on RBMN property shall be flush with top of ground.
- c. The distance from centerline of adjacent track to centerline of proposed manhole shall be shown on the plans.

4.12 BOX CULVERTS

- a. Reinforced concrete box culverts shall conform to the requirements of AREA Chapter 8, Parts 13 and 16.

4.13 DRAINAGE

- a. Occupancies shall be designated, and their construction shall be accomplished, so that adequate and uninterrupted drainage of RBMN's right-of-way is maintained.
- b. All pipes, ditches, and other structures carrying surface drainage on RBMN property and/or under RBMN track(s) shall be designed to carry the run-off from a one hundred (100) year storm. Computations indicating this design, prepared by a Professional Engineer, and suitable topographic plans, outlining the total drainage area, shall be submitted for RBMN's approval.
- c. If the drainage is to discharge into an existing drainage channel on RBMN's right-of-way and/or through a drainage structure under RBMN's track(s), the computations must include the hydraulic analysis of any existing ditch and/or structure.
- d. When calculating the capacity of existing or proposed drainage structures under RBMN's track(s), the headwater at the structure shall not be greater than one (1).
- e. Pipe(s) used to carry surface drainage on RBMN's right-of-way shall have a minimum diameter of 18 inches (457mm).
- f. Detention ponds must not be placed on any part of RBMN's right-of-way. Also, the railroad embankment must not be used as any part of a detention pond structure.
- g. Formal approval of the proposed design, by the appropriate governmental agency having jurisdiction, shall be submitted with the drainage computations.

4.14 PIPELINES ON BRIDGES

- a. Pipelines of any type shall not be installed on any bridge carrying RBMN tracks.
- b. New overhead pipe bridges shall not be constructed over RBMN's right-of-way where underground installation of the pipeline is possible. Where the Applicant can show

that no practicable alternative is available, this type of structure will be permitted provided the following conditions are met:

- ❑ The vertical clearance, distance from the top of the rail to bottom of structure, is shown and is a minimum of 23 feet (7.01m), measured at a point 6 feet (1.83m) horizontally from centerline track.
 - ❑ The support bents for the overhead structure are located off of RBMN's right-of-way or a minimum clear distance of 18 feet (5.5m) from centerline track, whichever distance is greater.
 - ❑ Support bents within 25 feet (7.6m) of centerline track have pier protection in accordance with AREA, Chapter 8, Part 2, Section 2.15.
 - ❑ Complete structural plans and design computations for the structure and foundations, stamped by a Professional Engineer, are submitted with the application.
 - ❑ A fence (with barbed wire) or other measures are provided which will prevent access to the bridge by unauthorized personnel or vandals.
- c. Pipelines carrying flammable substances or non-flammable substances, which by their nature might cause damage if escaping on or near railroad facilities or personnel, shall not be installed on bridges over RBMN tracks. In special cases when it can be demonstrated to RBMN's satisfaction that such an installation is necessary and that no practicable alternative is available, RBMN may permit the installation and only by special design approved by RBMN.
- d. When permitted, pipelines on bridges over RBMN tracks shall be so located as to minimize the possibility of damage from vehicles, railroad equipment, vandalism and other external causes. They shall be encased in a casing pipe as directed by RBMN (See Plate VII).

5.0 CONSTRUCTION REQUIREMENTS

5.1 METHOD OF INSTALLATION

5.1.1 General Requirements

- a. Bored, jacked or tunneled installations shall have a bore hole essentially the same as the outside diameter of the pipe plus the thickness of the protective coating.
- b. The use of water or other liquids to facilitate casing emplacement and soil removal is prohibited.
- c. If during installations an obstruction is encountered which prevents installation of the pipe in accordance with this specification, the pipe shall be abandoned in place and immediately filled with grout. A new installation procedure and revised plans must be submitted to, and approved by, RBMN before work can resume.

5.1.2 Open Cut

- a. The Owner must request open cut approval when making application for occupancy.
- b. Installations beneath the track by open trench methods will be permitted only with the approval of the Real Estate Department Director & General Manager Transportation of the division involved.

- c. Installations by open cut will not be permitted under mainline tracks, tracks carrying heavy tonnage or tracks carrying passenger trains. Also open cut shall not be used within the limits of a highway/railroad grade crossing or its approaches, 25 feet (7.6m) either side of traveled way, where possible.
- d. Rigid pipe (RCP, VCP and PCCP) must be placed in a Class B bedding or better.
- e. At locations where open cut is permitted, the trench is to be backfilled with crushed stone with a top size of the aggregate to be a maximum of 2 inches (51mm) and to have no more than 5% passing the number 200 sieve. The gradation of the material is to be such that a dense stable mass is produced.
- f. The backfill material shall be placed in loose 6 inch (152mm) lifts and compacted to at least 95% of its maximum density with a moisture content that is no more than 1% greater than or 2% less than the optimum moisture as determined in accordance with current ASTM Designation D – 1557 (Modified Proctor). When the backfill material is within 3 feet (9.1M) of the subgrade elevation (the interface of the ballast and the subsoil) a compaction of at least 98% will be required. Compaction test results confirming compliance must be provided to RBMN's Real Estate Department by the Owner.
- g. All backfilled pipes laid either perpendicular or parallel to the tracks must be designed so that the backfill material will be positively drained. This may require the placement of lateral drains on pipes laid longitudinally to the track and the installation of stub perforated pipes at the edge of the slopes.
- h. Unless otherwise agreed upon, all work involving rail, ties and other track material will be performed by railroad employees at the sole expense of the Owner.

5.1.3 Bore and Jack (Steel Pipe)

- a. This method consists of pushing the pipe into the earth with a boring auger rotating within the pipe to remove the soil.
- b. The boring operation shall be progressed according to inspector hours without stoppage (except for adding lengths of pipe) until the leading edge of the pipe has reached the receiving pit.
- c. The front of the pipe shall be provided with mechanical arrangements or devices that will positively prevent the auger from leading the pipe so that no unsupported excavation is ahead of the pipe.
- d. The auger and cutting head arrangement shall be removable from within the pipe in the event an obstruction is encountered. If the obstruction cannot be removed without excavation in advance of the pipe, procedures as outlined in Section 5.1.1c. must be implemented immediately.
- e. The over-cut by the cutting head shall not exceed the outside diameter of the pipe by more than ½ inch (13mm). If voids should develop or if the bored hole diameter is greater than the outside diameter of the pipe (plus coating) by more than approximately 1 inch (25 mm), grouting (see Section 5.2) or other methods approved by RBMN, shall be employed to fill such voids.

- f. The face of the cutting head shall be arranged to provide a reasonable obstruction to the free flow of soft or poor material.
- g. Plans and description of the arrangement to be used shall be submitted to RBMN for approval and no work shall proceed until such approval is obtained.
- h. Any method that employs simultaneous boring and jacking for pipes over 8 inches (203mm) in diameter that does not have the above approved arrangement WILL NOT BE PERMITTED. For pipe 8 inches (203mm) and less in diameter, augering or boring without this arrangement may be considered for use only as approved by RBMN.

5.1.4 Jacking (RCP and Steel Pipe)

- a. This method consists of pushing sections of pipe into position with jacks placed against a backstop and excavation performed by hand from within the jacking shield at the head of the pipe. Ordinarily 36 inch (914mm) pipe is the least size that should be used, since it is not practical to work within smaller diameter pipes.
- b. Jacking shall be in accordance with the current American Railway Engineering Association Specifications. Chapter 1, Part 4, "Jacking Culvert Pipe Through Fills." This operation shall be conducted without hand-mining ahead of the pipe and without the use of any type of boring, augering, or drilling equipment.
- c. Bracing and backstops shall be so designed and jacks of sufficient rating used so that the jacking can be progressed according to inspector hours without stoppage (except for adding lengths of pipe) until the leading edge of the pipe has reached the receiving pit.
- d. When jacking reinforced concrete pipe, a jacking shield shall be fabricated as a special section of reinforced concrete pipe with a steel cutting edge, hood, breasting attachments, etc. cast into the pipe. The wall thickness and reinforcing shall be designed for the jacking stresses.
- e. When jacking reinforced concrete pipe, grout holes, tapped for no smaller than 1½ inch (38mm) pipe, shall be cast into the pipe at manufacture. Three grout holes, equally spaced around the circumference and 4 feet (12.2m) longitudinally shall be provided for RCP 54 inches (1372mm) and smaller. Four grout holes, equally spaced around the circumference and 4 feet (12.2m) longitudinally shall be provided for RCP 60 inches (1524mm) and larger.
- f. Immediately upon completion of jacking operations, the installation shall be pressure grouted as per Section 5.2 of this specification.

5.1.5 Tunneling (Tunnel liner plate)

- a. This method consists of placing rings of liner plate within the tail section of a tunneling shield or tunneling machine. A tunneling shield shall be used for all liner plate installations unless otherwise approved by RBMN.
- b. The shield shall be of steel construction, designed to support a railroad track loading as specified in Section 4.1.3 of this specification, in addition to the other loadings imposed. The advancing face shall be provided with a hood, extending no

less than 20 inches (508mm) beyond the face and extending around no less than the upper 240 degrees of the total circumference. It shall be of sufficient length to permit the installation of at least one complete ring of liner plates within the shield before it is advanced for the installation of the next ring of liner plates. The shield shall conform to and not exceed the outside dimensions of the liner plate tunnel being placed by more than 1 inch (25.4mm) at any point on the periphery unless otherwise approved by RBMN.

- c. The shield shall be adequately braced and provided with necessary appurtenances for completely bulkheading the face with horizontal breastboards, and arranged so that the excavation can be benched as may be necessary. Excavation shall not be advanced beyond the edge of the hood, except in rock.
- d. Manufacturer's shop detail plans and manufacturer's computations showing the ability of the tunnel liner plates to resist the jacking stresses shall be submitted to RBMN for approval.
- e. Unless otherwise approved by RBMN, the tunneling shall be conducted continuously, according to inspector hours, until the tunnel liner extends at least beyond the theoretical railroad embankment line (See Plate III).
- f. At any interruption of the tunneling operation, the heading shall be completely bulkheaded.
- g. The liner plates shall have tapped grout holes for no smaller than 1 ½ inch (38mm) pipe, spaced at approximately 3 feet (0.9m) around the circumference of the tunnel liner and 4 feet (1.2m) longitudinally.
- h. Grouting behind the liner plates shall be in accordance with Section 5.2 of this specification.

5.1.6 Directional Boring/Horizontal Directional Drilling (Steel Pipe)

Method "A"

- a. This method consists of setting up specialized drilling equipment on existing grade (launching and receiving pits are not required) and boring a small diameter pilot hole on the desired vertical and horizontal alignment, using a mechanical cutting head with a high pressure fluid (bentonite slurry) to remove the cuttings. The drill string is advanced with the bentonite slurry pumped through the drill string to the cutting head and then forced back along the outside of the drill string, carrying the cuttings back to the surface for removal. When the cutting head reaches the far side of the crossing, it is removed and a reamer (with a diameter greater than the cutting head) is attached to the lead end of the drill string. The pipeline is attached to the reamer and the pilot hole is then back reamed while the pipeline is pulled into place.
- b. This method is used to place pipelines under rivers, wetlands and other obstructions which would be difficult to cross by conventional methods. The length of the bore is generally several hundred feet in length, with installations over a thousand feet possible.
- c. INSTALLATIONS BY THIS METHOD ARE GENERALLY NOT ACCEPTABLE, however, consideration will be given where the depth of cover is substantial, greater than 40

feet (12.2m), or the bore is in rock. Factors considered will be track usage, pipe size, contents of pipeline, soil conditions, etc.

- d. The following preliminary information must be submitted with the request for consideration of this type of installation.
- A site plan of the area
 - A plan view and profile of the crossing
 - A Pipe Data Sheet
 - Several soil borings along the proposed pipeline route.
 - A construction procedure, including a general description of equipment to be used.

If RBMN determines this method of installation is acceptable, final design plans and specifications are to be prepared and submitted for approval.

- e. The project specifications must require the contractor to submit, to RBMN for approval, a complete construction procedure of the proposed boring operation. Included with the submission shall be the manufacture's catalog information describing the type of equipment to be used.

Method "B"

- a. This method is used to place small diameter conduit for electric lines and other utilities. This method consists of using hydraulic jacking equipment to push a solid steel rod under the railroad from a launching pit to a receiving pit. At the receiving pit, a cone shaped "expander" is attached to the end of the rod and the conduit (casing pipe) is attached to the expander. The rod, expander and conduit are then pulled back from the launching pit until the full length of the conduit is in place.
- b. This method may be used to place steel conduit (casing pipe), up to and including 6 inches (152 mm) in diameter, under the railroad.
- c. The project specifications must require the contractor to submit to RBMN for approval, a complete construction procedure of the proposed boring operation. Included with the submission shall be the manufacture's catalog information describing the type of equipment to be used.

5.2 GROUTING

- a. For jacked and tunneled installations a uniform mixture of 1:6 (cement:sand) cement grout shall be placed under pressure through the grout holes to fill any voids which exist between the pipe or liner plate and the undisturbed earth.
- b. Grouting shall start at the lowest hole in each grout panel and proceed upwards simultaneously on both sides of the pipe.
- c. A threaded plug shall be installed in each grout hole as the grouting is completed at that hole.
- d. When grouting tunnel liner plates, grouting shall be kept as close to the heading as possible, using grout stops behind the liner plates if necessary. Grouting shall proceed as directed by RBMN, but in no event shall more than 6 lineal feet (1.8m) of tunnel be progressed beyond the grouting.

5.3 SOIL STABILIZATION

- a. Pressure grouting of the soils or freezing of the soils before jacking, boring, or tunneling may be required at the direction of RBMN to stabilize the soils, control water, prevent loss of material and prevent settlement or displacement of embankment. Grout shall be cement, chemical or other special injection material selected to accomplish the necessary stabilization.
- b. The materials to be used and the method of injection shall be prepared by a Registered Professional Soils Engineer, or by an experienced and qualified company specializing in this work and submitted for approval by RBMN before the start of work. Proof of experience and competency shall accompany the submission.

5.4 DEWATERING

- a. When water is known or expected to be encountered, pumps of sufficient capacity to handle the flow shall be maintained at the site, provided the contractor has received approval from RBMN to operate them. Pumps in operation shall be constantly attended on a 24-hour basis until, in the sole judgment of RBMN, the operation can be safely halted. When dewatering, close observation shall be maintained to detect any settlement or displacement of railroad embankment, tracks and facilities.

5.5 SAFETY REQUIREMENTS

- a. All operations shall be conducted so as not to interfere with, interrupt, or endanger the operation of trains nor damage, destroy or endanger the integrity of railroad facilities. All work on or near RBMN property shall be conducted in accordance with RBMN safety rules and regulations. The contractor shall secure and comply with the RBMN safety rules and shall give written acknowledgement to RBMN that they have been received, read and understood by the contractor and its employees. Operations will be subject to RBMN inspection at any and all times.
- b. All cranes, lifts, or other equipment that will be operated in the vicinity of the railroad's electrification and power transmission facilities shall be electrically grounded as directed by RBMN.
- c. At all times when the work is being progressed, a field supervisor for the work with no less than twelve (12) months experience in the operation of the equipment being used shall be present. If boring equipment or similar machines are being used, the machine operator also shall have no less than twelve (12) months experience in the operation of the equipment being used.
- d. Whenever equipment or personnel are working closer than 15 feet (4.6m) from the centerline of an adjacent track, that track shall be considered as being obstructed. Insofar as possible, all operations shall be conducted no less than this distance. Operations closer than 15 feet (4.6m) from the centerline of a track shall be conducted only with the permission of and as directed by, a duly qualified railroad employee present at the site of the work.
- e. Crossing the tracks at grade by equipment and personnel is prohibited except by prior arrangement with, and as directed by, RBMN.

5.6 BLASTING

- a. Blasting will not be permitted under or on RBMN's right-of-way.

5.7 TEMPORARY TRACK SUPPORTS

- a. When the jacking, boring or tunneling method of installation is used, and depending upon the size and location of the crossing, temporary track supports shall be installed at the direction of RBMN.
- b. Details of the temporary track supports shall conform to RBMN Standard PLATE XI
- c. The Owner's contractor shall supply the track supports with installation and removal performed by RBMN employees.
- d. The Owner shall reimburse RBMN for all costs associated with the installation and removal of the track supports.

5.8 PROTECTION OF DRAINAGE FACILITIES

- a. If, in the course of construction, it may be necessary to block a ditch, pipe or other drainage facility, temporary pipes, ditches or other drainage facilities shall be installed to maintain adequate drainage, as approved by RBMN. Upon completion of the work, the temporary facilities shall be removed and the permanent facilities restored.
- b. Soil erosion methods shall be used to protect railroad ditches and other drainage facilities during construction on and adjacent to RBMN's right-of-way.

5.9 SUPPORT OF EXCAVATION ADJACENT TO TRACK

5.9.1 Launching and Receiving Pits

- a. The location and dimensions of all pits or excavations shall be shown on the plans. The distance from centerline of adjacent track to face of pit or excavation shall be clearly labeled. Also, the elevation of the bottom of the pit or excavation must be shown on the profile.
- b. The face of all pits shall be located a minimum of 25 feet (7.6m) from centerline of adjacent track, measured at right angles to track, unless otherwise approved by RBMN.
- c. If the bottom of the pit excavation intersects the theoretical railroad embankment line (See Plate III) interlocking steel sheet piling, driven prior to excavation, must be used to protect the track stability. The use of trench boxes or similar devices are not acceptable in this area.
- d. Design plans and computations for the pits, stamped by a Professional Engineer, must be submitted by the Owner at time of application or by the contractor prior to

start of construction. If the pit design is to be submitted by the contractor, the project specifications must require the contractor to obtain RBMN's approval prior to beginning any work on or which may affect RBMN property.

- e. The sheeting shall be defined to support all lateral forces caused by the earth, railroad and other surcharge loads. See Section 4.1.3 for railroad loading.
- f. After construction and backfilling, all sheet piling within 10 feet (3.0m) of centerline track must be cut off 18 inches (457m) below final grade and left in place.
- g. All excavated areas are to be illuminated (flashing warning lights not permitted), fenced and otherwise protected as directed by RBMN.

5.9.2. Parallel Trenching and Other Excavation

- a. When excavation for a pipeline or other structure will be within the theoretical railroad embankment line (See Plate V) of an adjacent track, interlocking steel sheet piling will be required to protect the track.
- b. The design and construction requirements for this construction shall be in accordance with the requirements of Section 5.9.1.

5.10 INSPECTION AND TESTING

- a. For pipelines carrying flammable or hazardous materials, ANSI Codes, current at time of constructing the pipeline, shall govern the inspection and testing of the facility on RBMN property, except as follows:
 - One hundred percent of all field welds shall be inspected by radiographic examinations and such field welds shall be inspected for 100 percent of the circumference.
 - The proof testing of the strength of carrier pipe shall be in accordance with ANSI requirements.

5.11 REIMBURSEMENT OF RBMN COSTS

- a. All RBMN costs associated with the pipe installation (inspection, flagging, track work, protection of signal cables, etc.) shall be reimbursed to RBMN by the Owner of the facility. Reimbursement by the contractor is not acceptable.

PLATE I**PIPE DATA SHEET**

(For crossings and longitudinal occupancy)

	PIPE DATA	
	Carrier Pipe	Casing Pipe
Contents to be handled		
Normal operating pressure		
Nominal size of pipe		
Outside diameter		
Inside diameter		
Wall thickness		
Weight per foot		
Material		
Process of manufacture		
Specification		
Grade or class		
Test pressure		
Type of joint		
Type of coating		
Details of cathodic protection		
Details of seals or protection at ends of casings		
Method of installation		
Character of subsurface material at the crossing location		
Approximate ground water level		
Source of information on subsurface conditions (borings, test pits or other)		

NOTE: Any soil investigation made on railroad property or adjacent to tracks shall be carried on under the supervision of RBMN (See Section 1.4)

PLATE II

INFORMATION TO BE SHOWN ON PLAN VIEW OF DRAWINGS
WHEN FACILITY IS A CROSSING

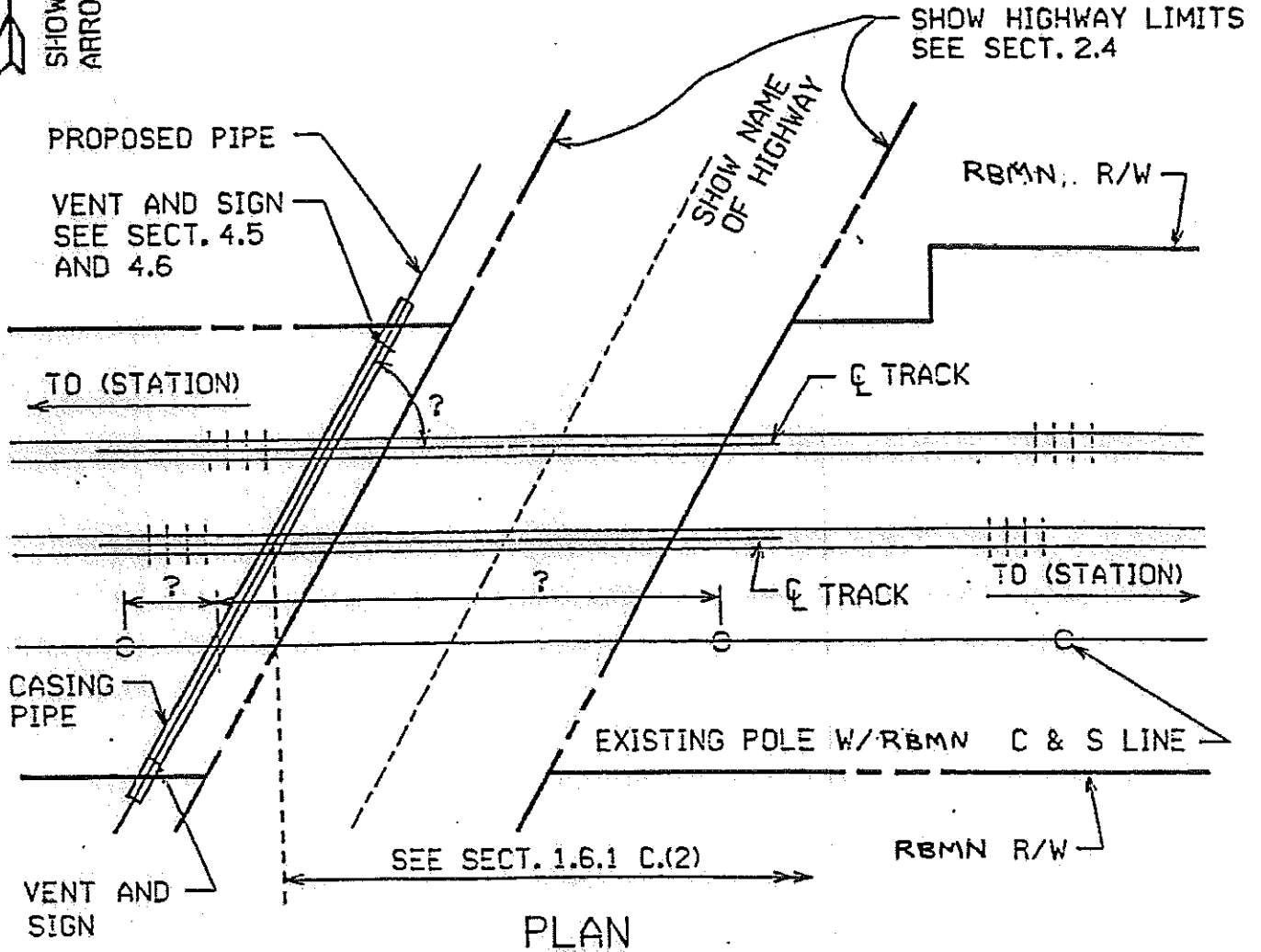

PLAN

SCALE OF DRAWING TO BE SHOWN

NOTES:

IF THE PROPOSED LINE IS WITHIN HIGHWAY LIMITS, THE SAME INFORMATION IS REQUIRED AS SHOWN ON THIS PLATE.

IF THE PROPOSED PIPE IS TO SERVE A NEW DEVELOPMENT, A MAP SHOWING THE AREA IN RELATION TO ESTABLISHED AREAS AND ROADS IS TO BE SENT WITH THE REQUEST.

PLATE III

PIPELINE CROSSING

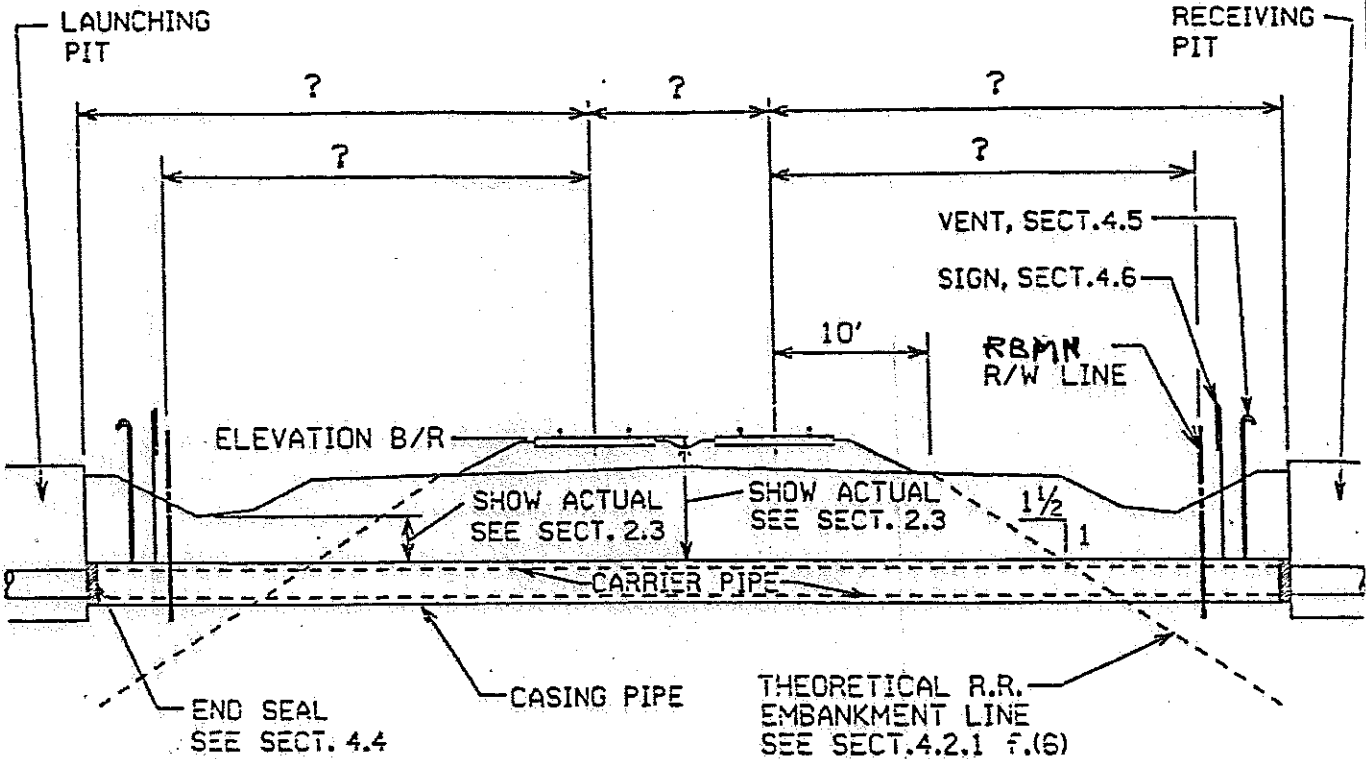

PROFILE

SCALE OF DRAWING TO BE SHOWN

PLATE IV
LONGITUDINAL OCCUPANCY

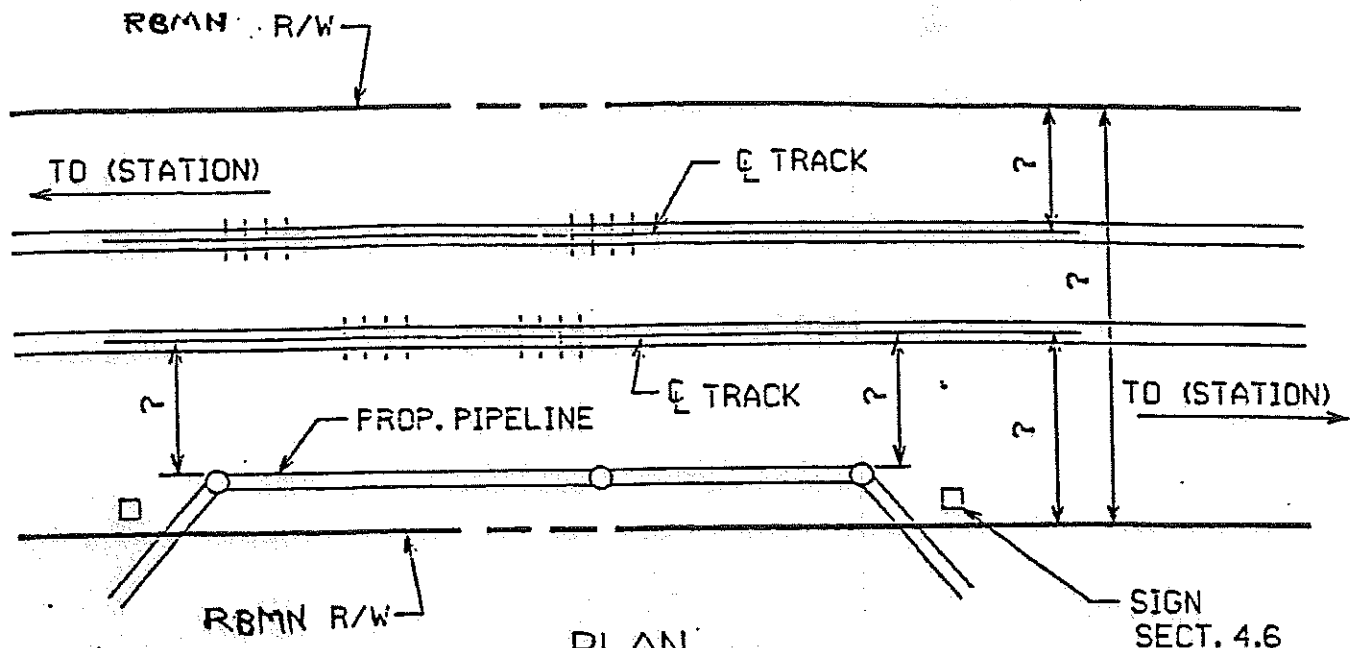

PLAN -SEE SECT. 1.6

SCALE OF DRAWING TO BE SHOWN

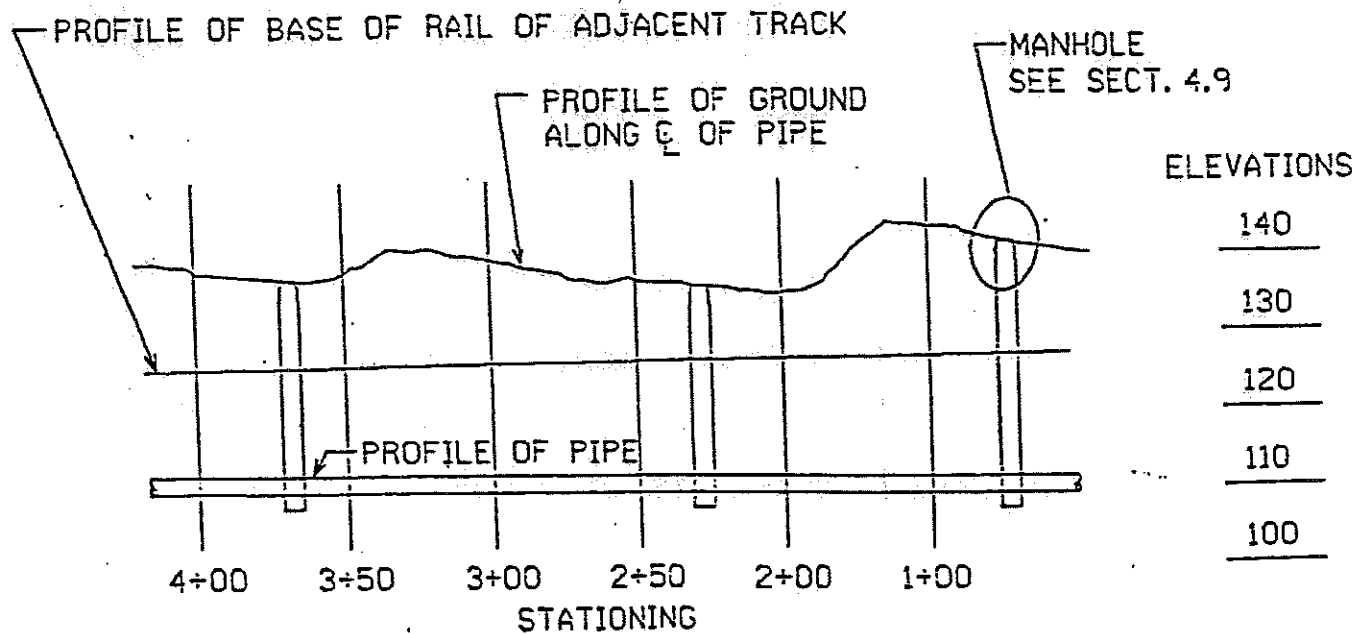

PROFILE -SEE SECT. 1.6

SCALE: HORIZ.: _____
 VERT.: _____

PLATE V

LONGITUDINAL OCCUPANCY

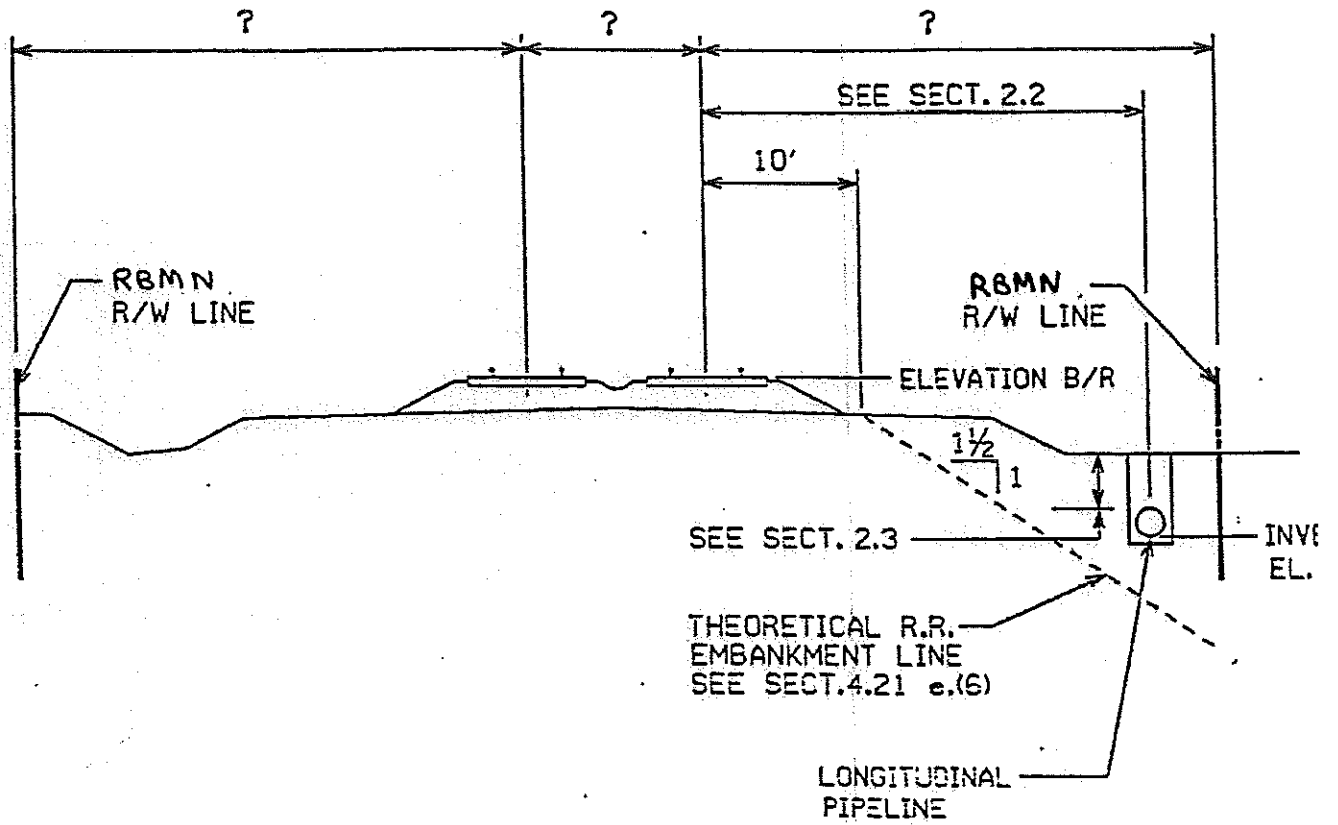

SECTION

SCALE OF DRAWING TO BE SHOWN

NOTE: SECTIONS TO BE TAKEN EVERY 500 FEET (MAX.).

PLATE VI

PIPELINE IN HIGHWAY UNDER RAILROAD BRIDGE

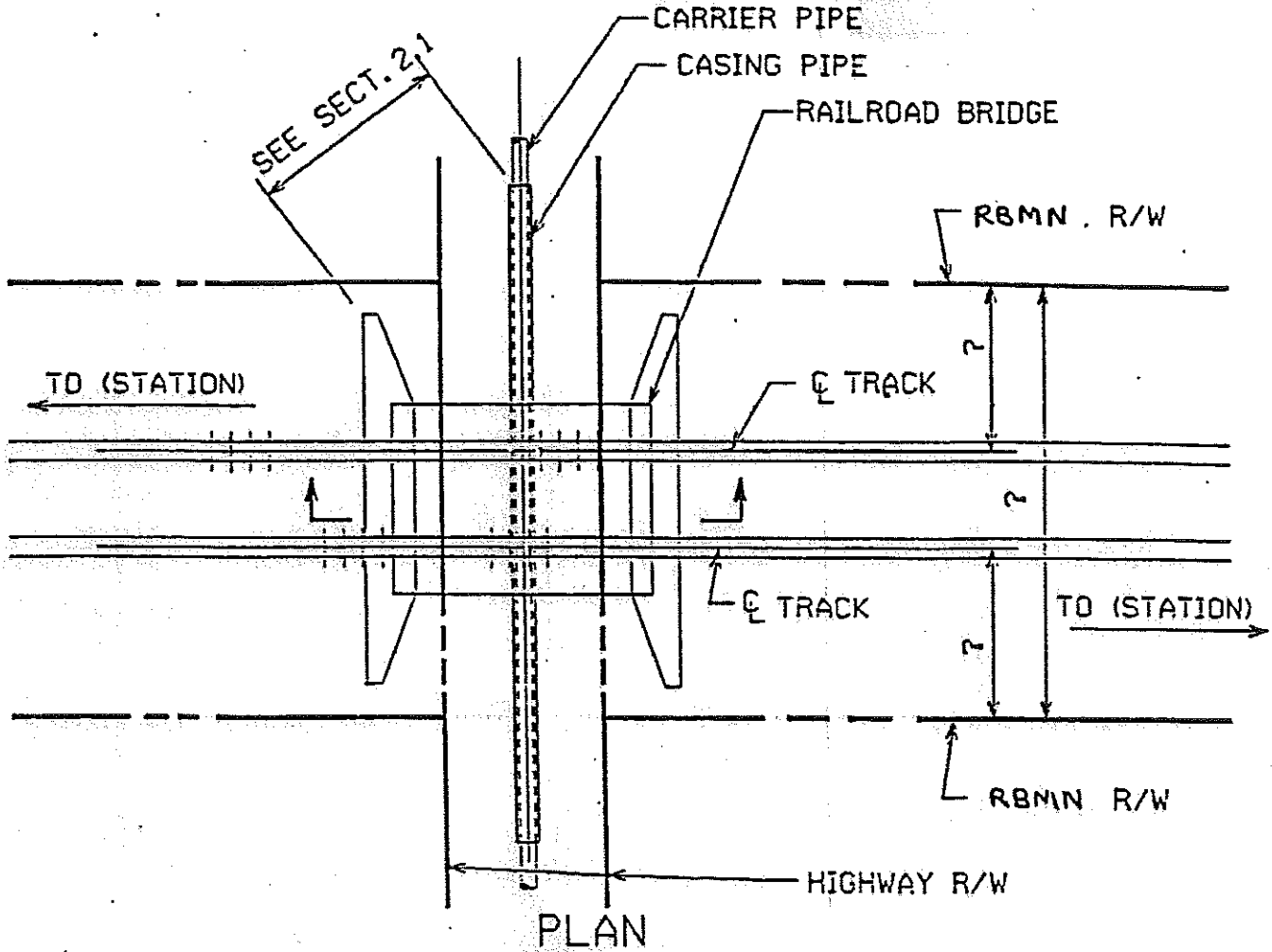

PLAN

SCALE OF DRAWING TO BE SHOWN

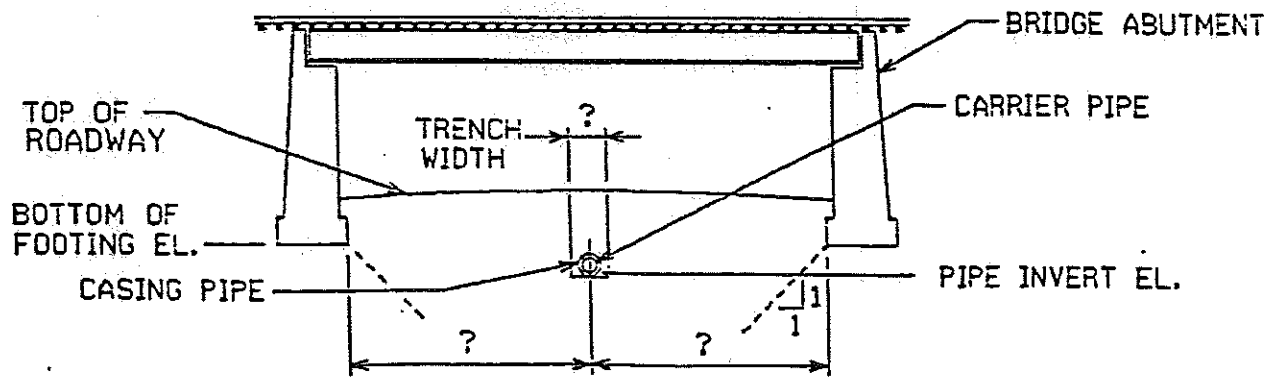

SECTION

SCALE OF DRAWING TO BE SHOWN

NOTE: PIPE OR EXCAVATION MUST NOT BE WITHIN THE 1 TO 1 SLOPE LINE THAT EXTENDS FROM BOTTOM OF FOOTING.

PLATE VII

PIPELINE ON HIGHWAY BRIDGE OVER RAILROAD

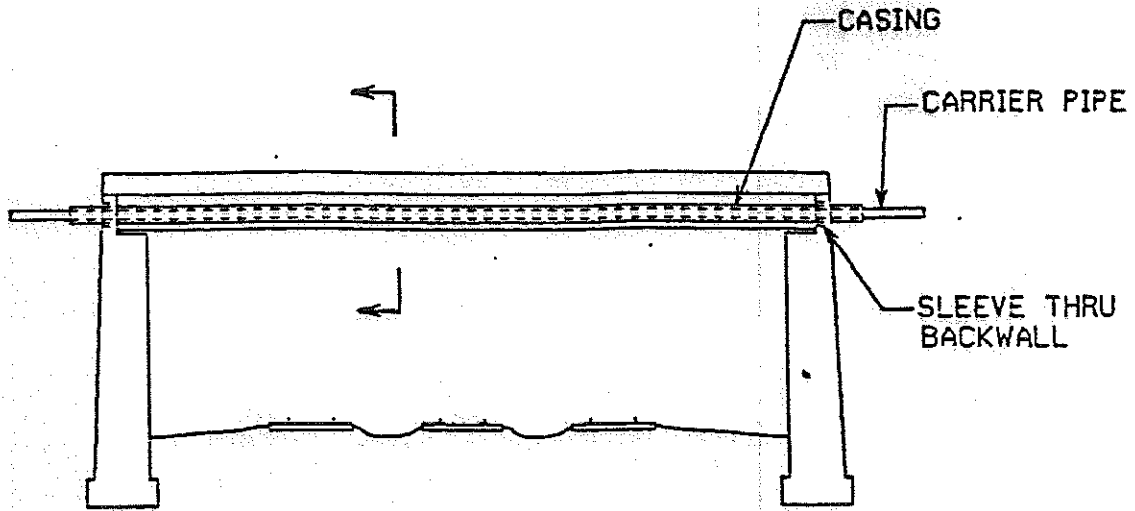

ELEVATION

SCALE OF DRAWING TO BE SHOWN

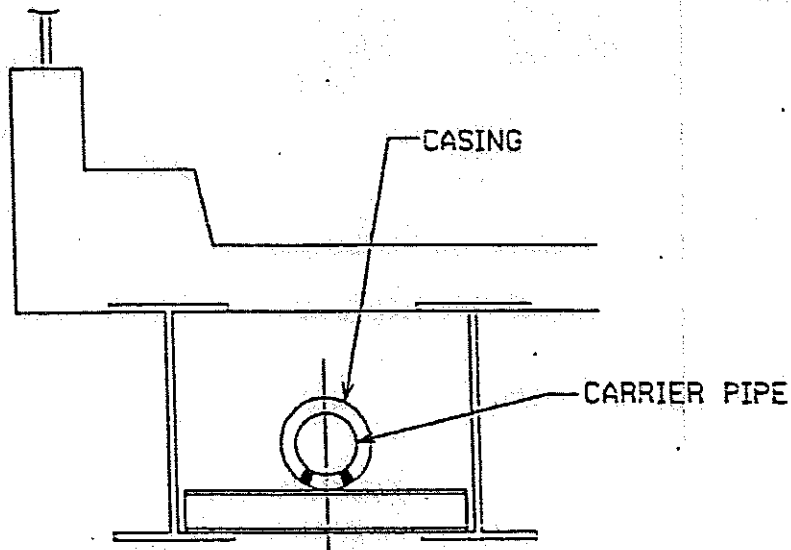

SECTION

SCALE OF DRAWING TO BE SHOWN

PLATE IX

LATERAL PRESSURE DIAGRAM

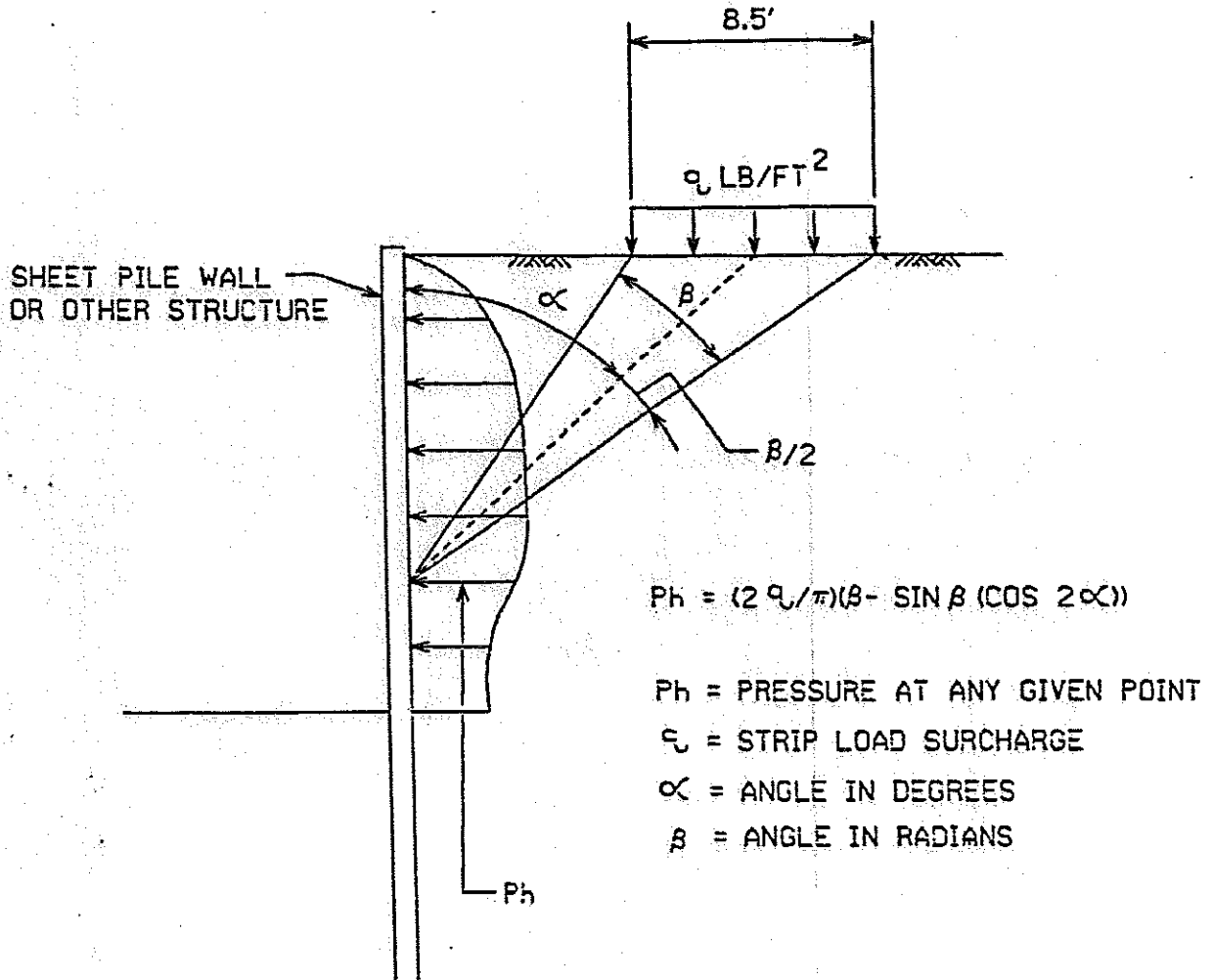

ELEVATION

LATERAL PRESSURE DUE TO STRIP LOAD

PLATE X

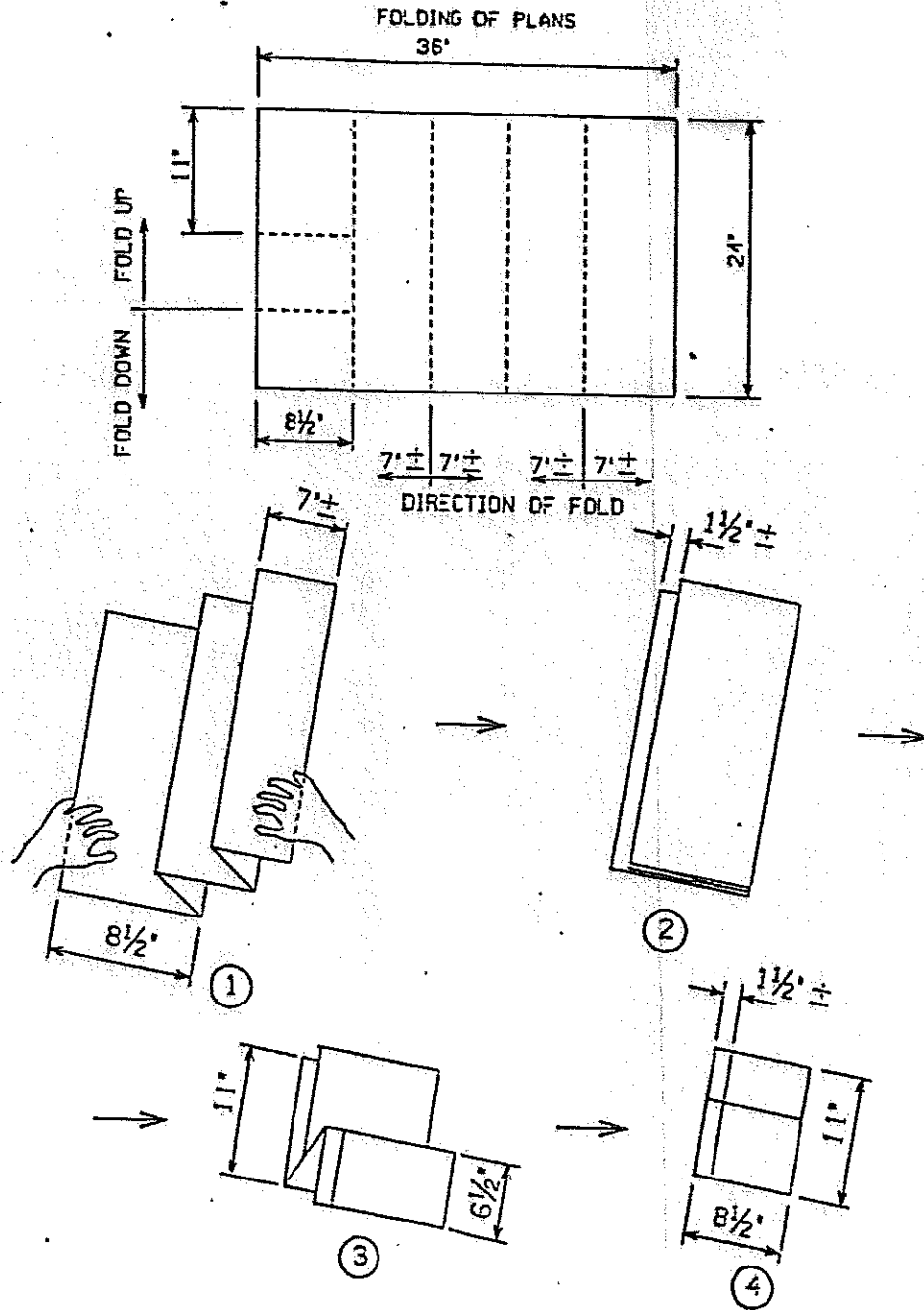

PUBLICATION STANDARDS SOURCES

ANSI American National Standards Institute, Inc.
1430 Broadway
New York, NY 10018
(212) 642-4900

AREA American Railway Engineering Association
50 F Street N.W.
Washington, DC 20001
(202) 639-2190

ASTM American Society for Testing and Materials
1916 Race Street
Philadelphia, PA 19103-1187
(215) 299-5585

AWWA American Water Works Association, Inc
6666 West Quincy Avenue
Denver, CO 80235

The National Association of Corrosion Engineers
Houston, TX 77026

NOTE:

If other than AREA, ASTM or AWWA specifications are referred to for design, materials or workmanship on the plans and specifications for the work, then copies of the applicable sections of such other specifications referred to shall accompany the plans and specifications for the work.